

Technical data sheet of the product: The metal device is protective, anti-vandal - MDPA-2inox

Attention: Before using the product, read the operating information below. This manual contains basic instructions that must be followed during installation, operation and maintenance of the product.

1. APPOINTMENT

The TM ARMA DETECT protection device is produced of AISI 304 (A2) metal, stainless steel. It is used for mechanical protection of automation devices - a water leakage detector, which can be found on the official website of the manufacturer.

2. TECHNICAL SPECIFICATION

All parts of the device are made of chemically resistant stainless steel metal in accordance with TY Y 25.7-29326917482-001:202 and meet the technical requirements in force on the territory of Ukraine.

Ukrainian Classifier of Goods (УКТ ЗЕД) – 8302 (Fixing fittings, fittings and similar products from base metals).

Installation kit:

- Screw in the amount of - 2 pcs,
- Plastic dowel in the amount of - 2 pcs.

The installation kit ensures secure mounting of the motion detector on a surface (wall or ceiling). It is used to fix the protective reinforced product itself to the surface. The product helps to strengthen the protection against external interference and vandalism in the correct operation of the detector, and makes it impossible to quickly dismantle it from the place of previous installation.

3. PRODUCT IMAGE

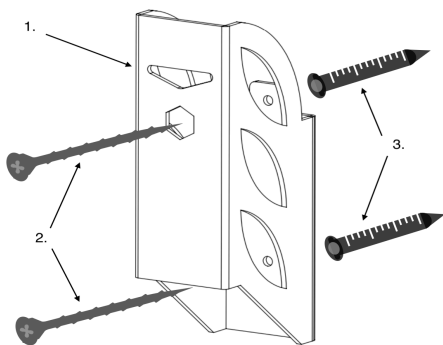

- 1. Frame 140x60x40x1.5mm - 1 pcs.
- 2. Screw 4x40mm - 2 pcs.
- 3. Spacer dowel 6x35 - 2 pcs.

4. INSTALLATION RULES AND RECOMMENDATIONS

You will need:

- electric or manual drill;
- a puncher if the floor is concrete;
- a tape measure for measuring the distance;
- screwdriver with a set of bits;
- hammer and hand punch;
- 6x110 SDS drill bit for a perforator drill SDS.

Install the protection on the surface as follows:

- mark the location of the four holes using the sticker from the kit;
- drill holes with a drill that correspond to the dimensions of the sticker;
- install the dowels in the holes previously cleaned of crumbs/dust;
- install the sleeves first, fix them with screws. Install the plate on the bushings and screw in the decorative screws.

Additional recommendations:

- Drill bit oscillation at the beginning of drilling can be eliminated by punching a small hole with a light punch.
- To prevent the floor from crumbling, reduce the diameter of the drill bit. And in the case of ceramic tiles, use a drill bit for ceramics/glass.
- The depth of the holes is controlled by a mark on the drill bit.

5. OPERATING REQUIREMENTS

Before starting operation, be sure to check the integrity of all structural elements, fasteners (screws) and decorative caps. If necessary, you should ensure the presence of these elements yourself.

The operating temperature of the product is from: - 35° to + 65°C.

However, it should be noted that the operating temperature of the motion detector ranges from -10° to +40°C.

6. WARRANTY

The warranty period for the product is two years from the date of manufacture.

The standard service life of the product in interaction with the environment is at least 20 years.

The warranty covers any product defects caused by manufacturing and material defects.

The terms of the warranty card do not apply to logistics services (return/exchange of goods).

The warranty does not cover product defects in the following cases:

1. The warranty card is lost or replaced.
2. The date of sale is missing.
3. The equipment was damaged during transportation from the place of purchase to the place of installation.
4. In case the consumer has changed the product configuration.
5. Use of the product in violation of the operating requirements.
6. Mechanical damage to the products during transportation, as a result of impact or falling, or the use of force;
7. Exposure to low or high temperatures not specified in the operating instructions;
8. Incorrect installation of the product.
9. In case of damage (deformation, subsidence) of the installation site.
10. In case of paint application. Aggressive liquids on the surface of the product.

Procedure for reviewing complaints

1. Claims for visible (visual) damage are considered within two weeks from the date of sale.
2. The buyer must fill out a complaint report and send a photo or video of the defect to the mail: info@armadetec.com.
3. Consideration and decision on the complaint is made within seven business days.

7. WARRANTY CARD

Vendor.....

Date of sale.....